

Basic technical rider for  
**Abdoulaye Diabate & Super Manden** Backstage

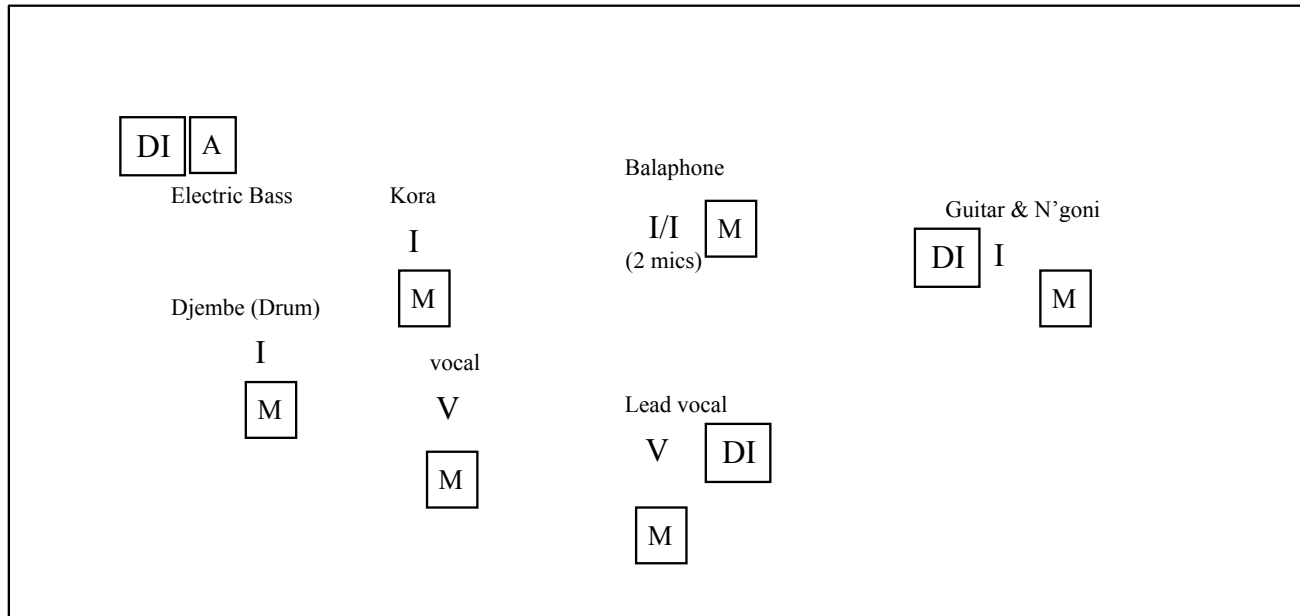

V = Vocal mic  
 I = Instrument mic  
 All mics on boom stands

**Kora is a 21 string hand-held harp/lute  
 Balaphone is similar to a marimba  
 N'goni is like a small guitar**

**A** = Amplifier (Bass amplifier provided by presenter)  
**M** = Monitor  
**DI** = Direct input

Contact: Kaisha S. Johnson  
 kjohnson@ctmd.org  
 (212) 571-1555 x23